

devoted to **PERFECT** grinding



DIP.[®]
GRINDERS

DK-200

KINEMATIC SCHEME

Grinder

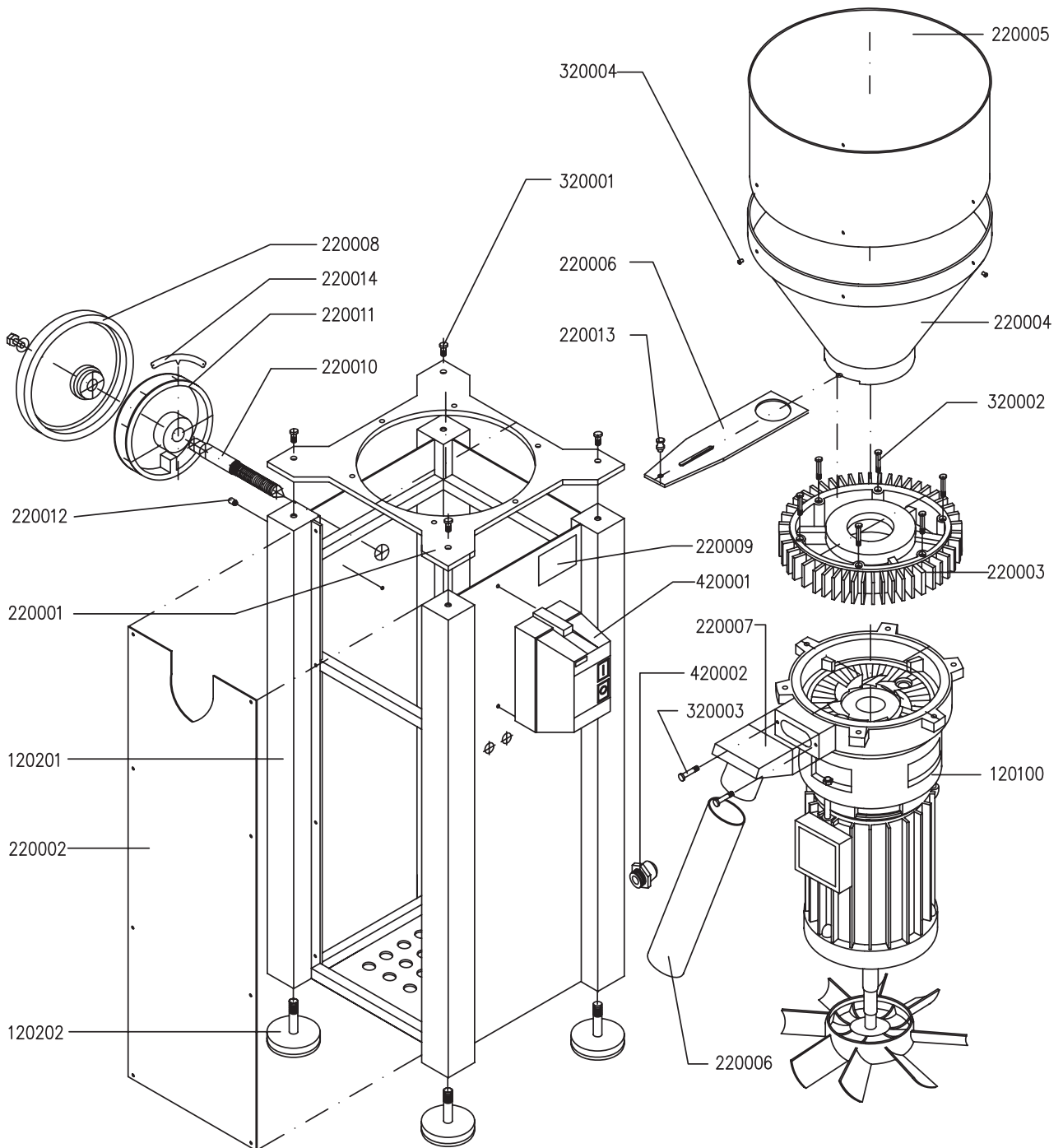

COFFEE GRINDER
120000

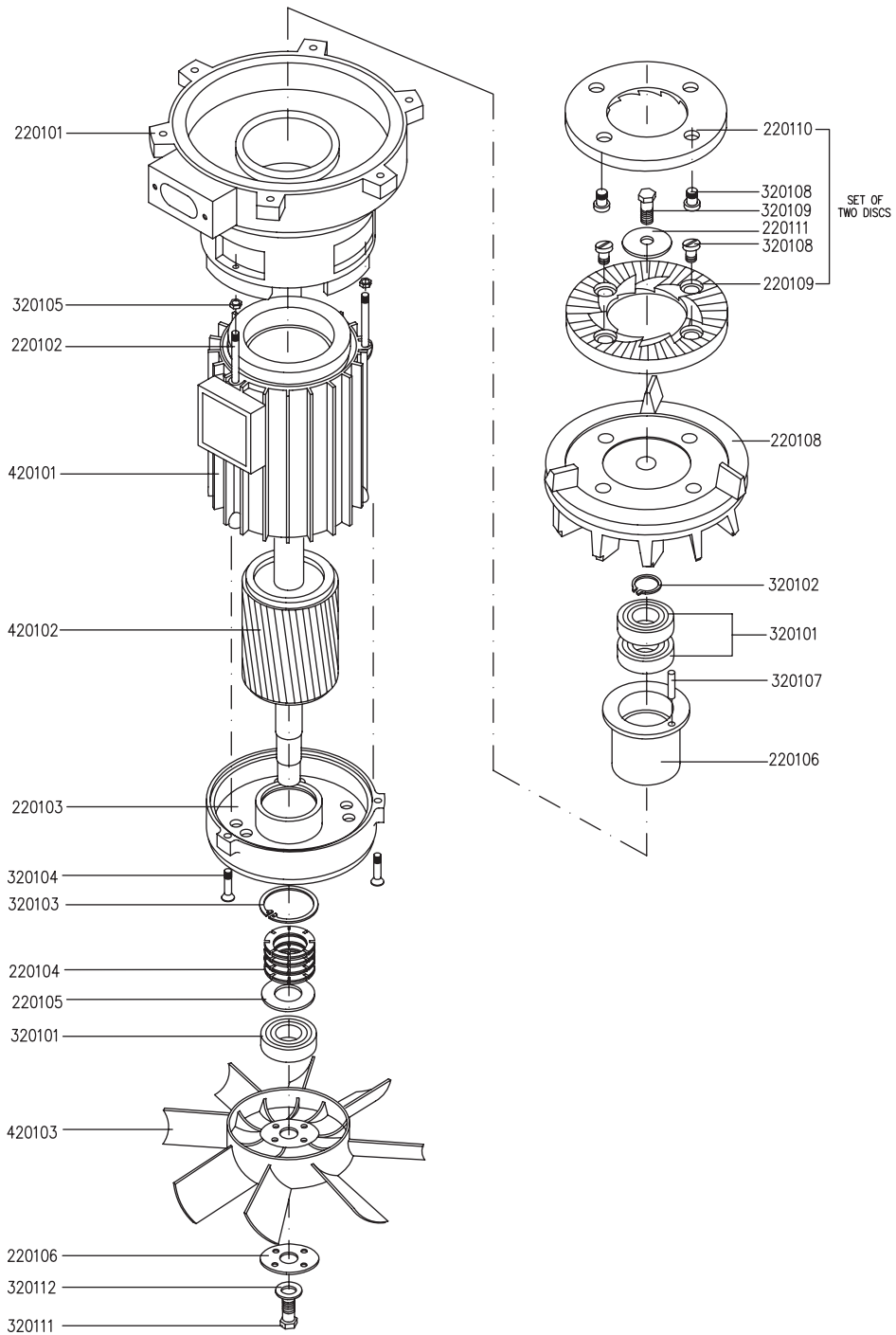
Grinding mechanism

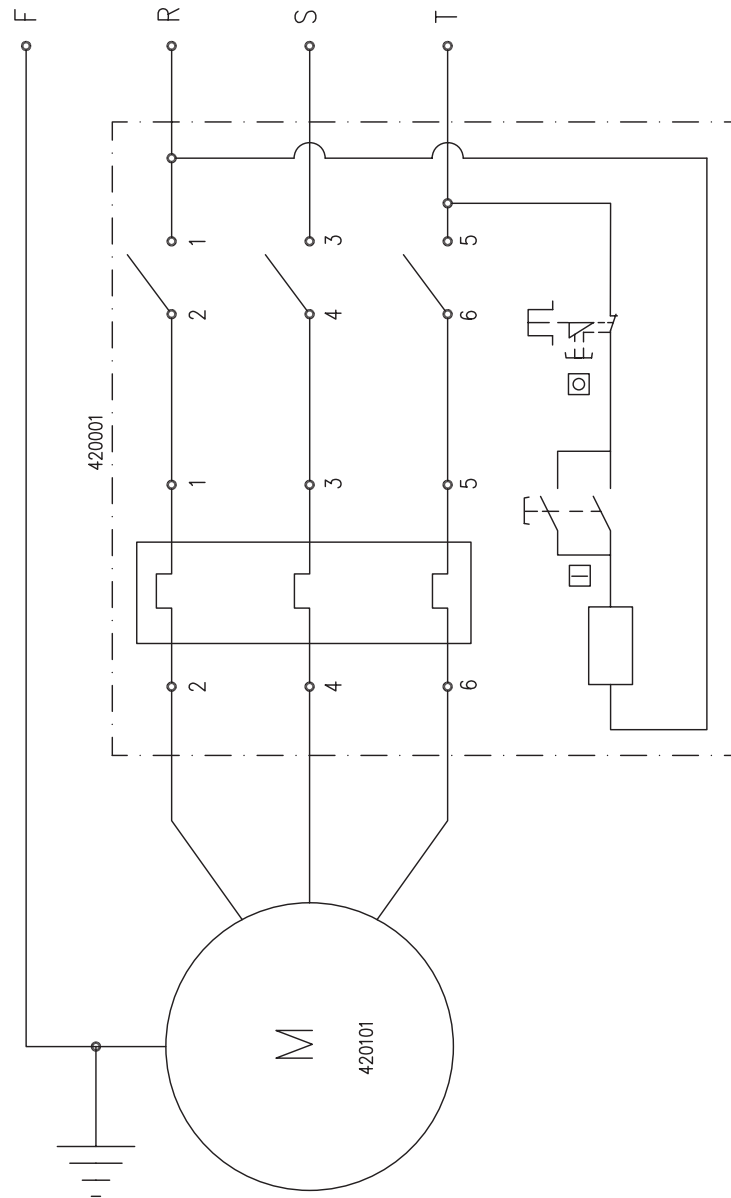

GRINDING MECHANISM	120100
---------------------------	---------------

Electrical diagram



devoted to **PERFECT** grinding



DIP.[®]
GRINDERS

HEAD OFFICE:

287 Theodor Pallady Bd. 032258 Bucharest, Romania
Phone: +40 21 345 11 06 • Fax: +40 21 345 11 07
www.dipgrinders.ro • office@dipgrinders.ro