

DK-50
DK-60

SPEEDY
AND
PRECISE



devoted to **PERFECT** grinding

A large, stylized graphic of coffee grinder gears. The gears are rendered in a light grey color, with several segments highlighted in a vibrant pink color. The gears are arranged in a circular pattern, creating a sense of motion and mechanical complexity.

INSTRUCTION MANUAL

**COFFEE GRINDER
MODEL DK-50/DK-60**

DIP. [®]

M A C H I N E

www.dipgrinders.com

INDEX

- 1. GENERAL DATA**
- 2. INTRODUCTION: CONSERVATION OF THE HANDBOOK**
- 3. CONTEMPLATED USE AND WARNING**
- 4. INSTALLATION – LOCATION – START-UP**
- 5. MAINTENANCE**
- 6. SHUT-DOWN AND DISMANTLING**
- 7. TECHNICAL DATA AND DIAGRAM**

1. GENERAL DATA

MANUFACTURER:

DIP IMPEX SRL

HEAD OFFICE

287 Theodor Pallady Bd.

Bucharest 032258

ROMANIA

Phone: +40 21 345 1106

Fax: +40 21 345 1107

Website: www.dipgrinders.ro

Email: office@dipgrinders.ro

MODEL:

DK-50 / DK-60

VERSION:

220-230 V / 50-60 Hz

380-400 V / 50-60 Hz

110-120 V / 60 Hz

YEAR OF MANUFACTURE

2015

LOCAL AGENT (Stamp below):

2. INTRODUCTION: CONSERVATION OF THE HANDBOOK

The manual is intended for the machine's user and/or maintenance technician.

The object of this manual is to provide information for the correct use of the machine and proper maintenance, as well as to guarantee the safety of the operator.

This manual must be carefully retained, since **the manufacturer accepts no responsibility for damage to people or things, or suffered by the machine if it is used in other ways than that describe there in** or if the maintenance and safety prescriptions are not complied with.

This manual must be always available to the user and/or maintenance technician, who must be informed of the correct use of the machine and possible hidden risks. It must be kept in a dry, clean place.

The information given in this manual does not replace the safety instructions and technical data for the installation and operating directly affixed to the machine and packaging.

This manual must be considered as part of the machine and must be kept for the future reference until it is dismantled.

If you want further information, contact your area agent or the manufacturer.

This manual reflects the state of the art at the current time and cannot be considered inadequate merely because it is updated later on the basis of new developments.

The manufacturer also reserves the right to modify the manual without the duty of updating earlier issues, only in exceptional cases.

If the machine is used incorrectly or in ways other than described in this manual it will render any guarantee or manufacturer's responsibility condition null and void; a responsible adult should use it.

3. CONTEMPLATED USE AND WARNINGS

The coffee grinder is an appliance for grinding coffee beans.

Average operating time is 10 years.

Its long-lasting, non-toxic components are easily accessible for proper cleaning and maintenance.

The user must be an adult (must be over 18 years old). Children or unsuitable people must not use the machine.

The user must comply with the safety regulations in force in the country of installation, as

well as with the rules dictated by common sense, and ensure that routine maintenance is carried out regularly and correctly.

The installer, the user and the maintenance technician must inform the manufacturer of possible faults or wear which could affect the system's original safety.

The installer must check that the environmental conditions are suitable, so as to guarantee safety and hygiene for the operators and users.

The various manufacturers are responsible for the commercial components fitted to the machine; the customer is responsible for the people authorized to use the machine.

Do not expose the machine to the sun, rain, snow, etc.

Safety Precaution

This appliance must be used only for the purpose to which it was specifically designed, namely for **grinding coffee beans**. Any other use will be considered unsuitable and therefore hazardous. The manufacturer cannot be held responsible for any possible damage caused by unsuitable, incorrect or unreasonable use.

Basic rules:

- Do not touch the appliance with damp or wet hands.
- Do not use the appliance in bare feet.
- Although the machine is earthen, **we recommend the use of a centralized life-saving system** to prevent the risk of electric shocks.
- Do not tug on the power flex or the appliance itself to disconnect the plug from the socket.
- **Do not allow the appliance to be used by children or unsuitable persons.**
- Before carrying out any cleaning or maintenance, disconnect the appliance from the electrical main network by removing the plug.
- Do not use jets of water or detergents .
- **In the case of a fault or malfunction of the appliance switch it off and do not tamper with it.** If it needs repairs, use only an authorized technical service center and ask for original spare parts to be used. If you don't do that you will affect the appliance's safety.
- Do not leave the appliance plugged in unnecessarily. Unplug it from the power supply when it is not in use.
- Do not block the ventilation and heat dispersal openings and louvers and do not introduce water or any type of liquid into them.
- **If the flex is damaged it should be replaced as soon as possible.**

- When the appliance is working **never insert spoons, forks or other utensils into the container** to extract samples or make interventions.
- Never immerse the motor base in water.

4. INSTALLATION – LOCATION – START-UP

Precautions for installation

The manufacturer has obviously taken every possible precaution to guarantee user safety, but the different installation and/or transport conditions could give rise to uncontrollable or unpredictable conditions; **so it is always necessary to assess possible hidden hazards** and to consider the following suggestions:

- **The packing elements** (cardboard, metal staples, etc) can cut, wound or cause accidents if they are not handled carefully or if they are used incorrectly; do not leave them accessible to children or to unsuitable people.
- **Any fault or defect** should be promptly notified to the personnel who are authorized to carry out installation and maintenance.
- **An earth connection is mandatory**, as is the system's conformity with the regulations in force in the country of installation. The manufacturer accepts no responsibility for accidents due to non-compliance with regulations.
- **The use of extensions or flying connections is prohibited.** The working environment is heavily exposed to water and damp which prevents the natural conditions for insulating the system.
- **Only authorized, qualified personnel must install the machine.**
- Check the condition of the components and, should defects or faults arise, stop the installation and ask for their replacement.
- **Ensure that the power supply voltage** (see rating plate) is the same as that of the main supply network to be used in the place of installation.
- **The customer must provide for the machine's power supply, protecting the line** with a suitable safety cutout (lifesaver).

Start-up

Attention: the earth connection is mandatory.

After you have made the electrical connection, remove the container's lid and put the coffee beans into it. Put the bag (in which the grind coffee will go) and fix the bag between the nose and the discharge tube. Push the on/off switch and grind coffee.

5. MAINTENANCE

Cleaning operations

Before cleaning the machine turn the main switch off and unplug the power cord.

Use a damp cloth (not abrasive) for cleaning the base and the outer case. Never use alcohol or solvents on the written or painted parts.

Maintenance operations

Specialized personnel authorized by the manufacturer must do maintenance.

Do not perform makeshift or ad-hoc repairs, and never use non-original spare parts.

ALWAYS UNPLUG THE ELECTRICITY when carrying out maintenance checks or operations.

Cleaning operation and replacing the discs.

- **UNPLUG THE GRINDER.**
- Remove the plastic hopper (item nr. 2460501)
- Dismantle the aluminum cover (item nr. 360111)
- Take apart the upper grinder disc from the aluminum cover (item nr. 260110)
- Take apart the lower grinder disc from the bottom side of grinder chamber (item nr. 260109)
- With a brush, clean the grinder discs, clean the rotor (item nr. 260108) blades from coffee and the discharge tube (item nr. 260007), (eventually it is possible to use compressed air for those operations).

ADJUSTING THE GRIND

1. Make sure the discs are clean with no coffee or dirt particles on the underside.
2. Install **one** disc on the rotating disc and the other on the stationary disc, making sure the screws are tight.
3. Make sure that the top edges of the grinding chamber and the underside of the stationary disc are perfectly clean.
4. Adjust the grind setting to #9.
5. Align the screw holes of the stationary disc with the grinding chamber and insert the screws tightly.
6. Replace the cover with the plastic hopper. Now you can plug the grinder in.
7. With the adjustment knob (item nr. 230004) on #9 (French Press), turn the

grinder on.

8. With the motor running, adjust the grind towards #1 slowly until you hear metal scraping. (If you do not hear a metallic sound when you reach #1, pull the knob away from the grinder and, while pulled out, set the #9 in front of the red line and adjust the grind towards #1 as above).
9. Notice the position of the adjusting knob when you first hear metal sound. Increase the adjustment setting counter-clockwise by one line (or half a setting).
10. Pull the adjusting knob away from the grinder housing and, with it pulled, position the #1 to be in front of the red arrow.
11. Grind a handful of beans on #1, and the output should be a powder. After completion, on any setting, YOU SHOULD NEVER HEAR METAL SOUND.
12. Tighten the screw in the center of the adjusting knob.
13. **IF YOUR GRIND IS NOT POWER, REPEAT THE INSTALLATION SECTION.**

6. SHUT-DOWN AND DISMANTLING

Whenever it is decided that an appliance of this type will no longer be used, it is recommended to make it inoperable by cutting the power cord after having disconnected the plug from the power socket. It is also recommended to make those parts of the appliance liable to create hazard danger-proof.

Store the machine in a suitable place, out of reach of children or unsuitable people.

For dismantling as refuse, deliver the appliance to an authorized refuse collection center.

Do not dispose of it in the environment.

7. TECHNICAL DATA AND DIAGRAM

Coffee Grinder DK-50

Voltage:	220-240 V / 50-60Hz or 380 V / 50-60 Hz or 110-120 V / 60 Hz
Motor power:	1500 W
Average output:	2000 g/min*
Hopper capacity:	1300 g
Grinding disc diameter:	120 mm
Weight:	32 Kg
Dimensions (W x D x H):	210x210x610 mm

Coffee Grinder DK-60

Voltage:	380-400V / 50-60Hz
Motor power:	1500 W
Average output:	2200 g/min*
Hopper capacity:	1300 g
Grinding disc diameter:	140 mm
Weight:	35 Kg
Dimensions (W x D x H):	210x210x610 mm

***The output can be varied according to the type of coffee bean-sand and the method of roasting.**

D.I.P. IMPEX SRL, 287 Theodor Pallady Bd., Bucharest -032258, Romania

Phone: +4-0213451106 • Fax: +40213451107

www.dipgrinders.ro • office@dipgrinders.ro

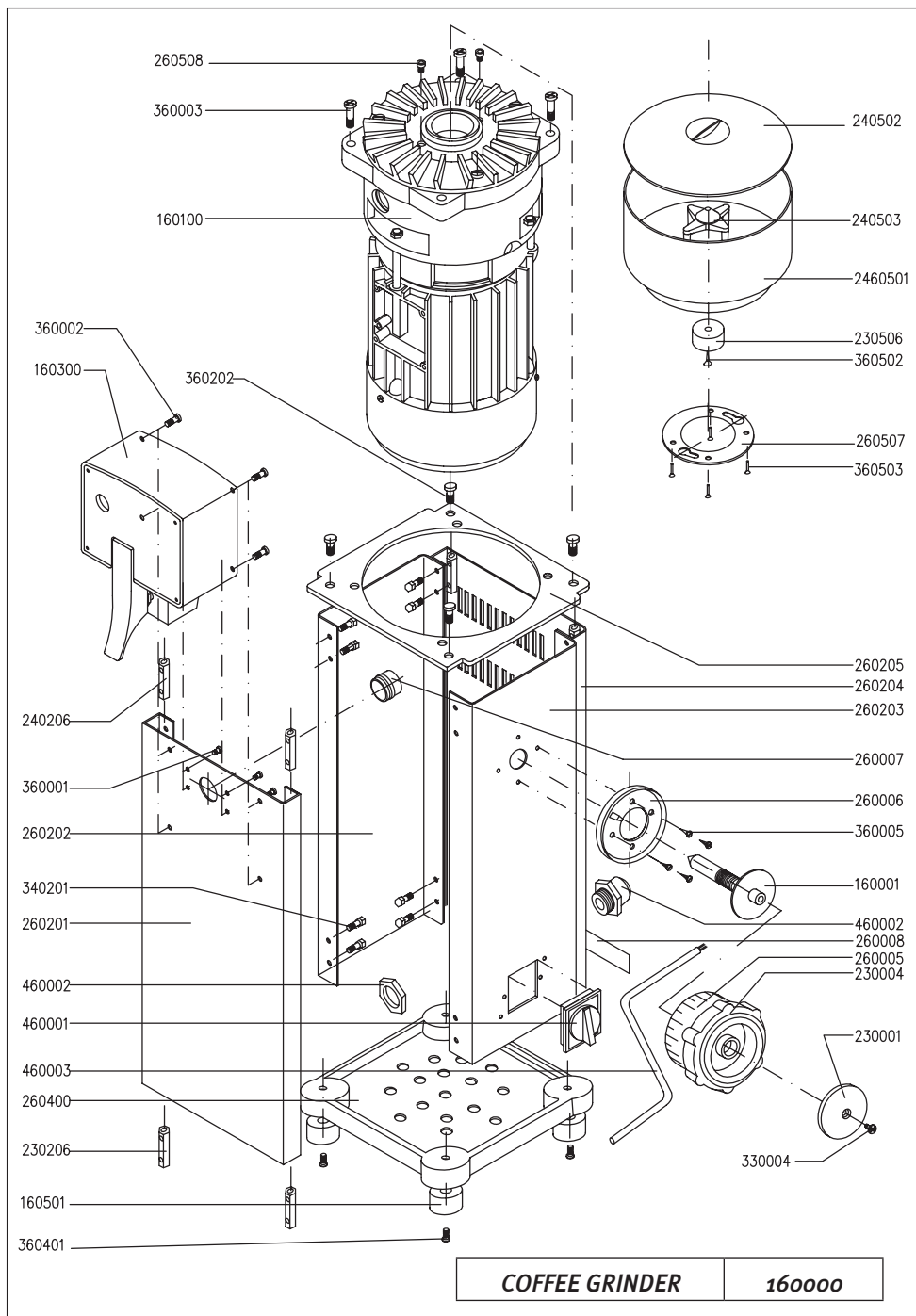

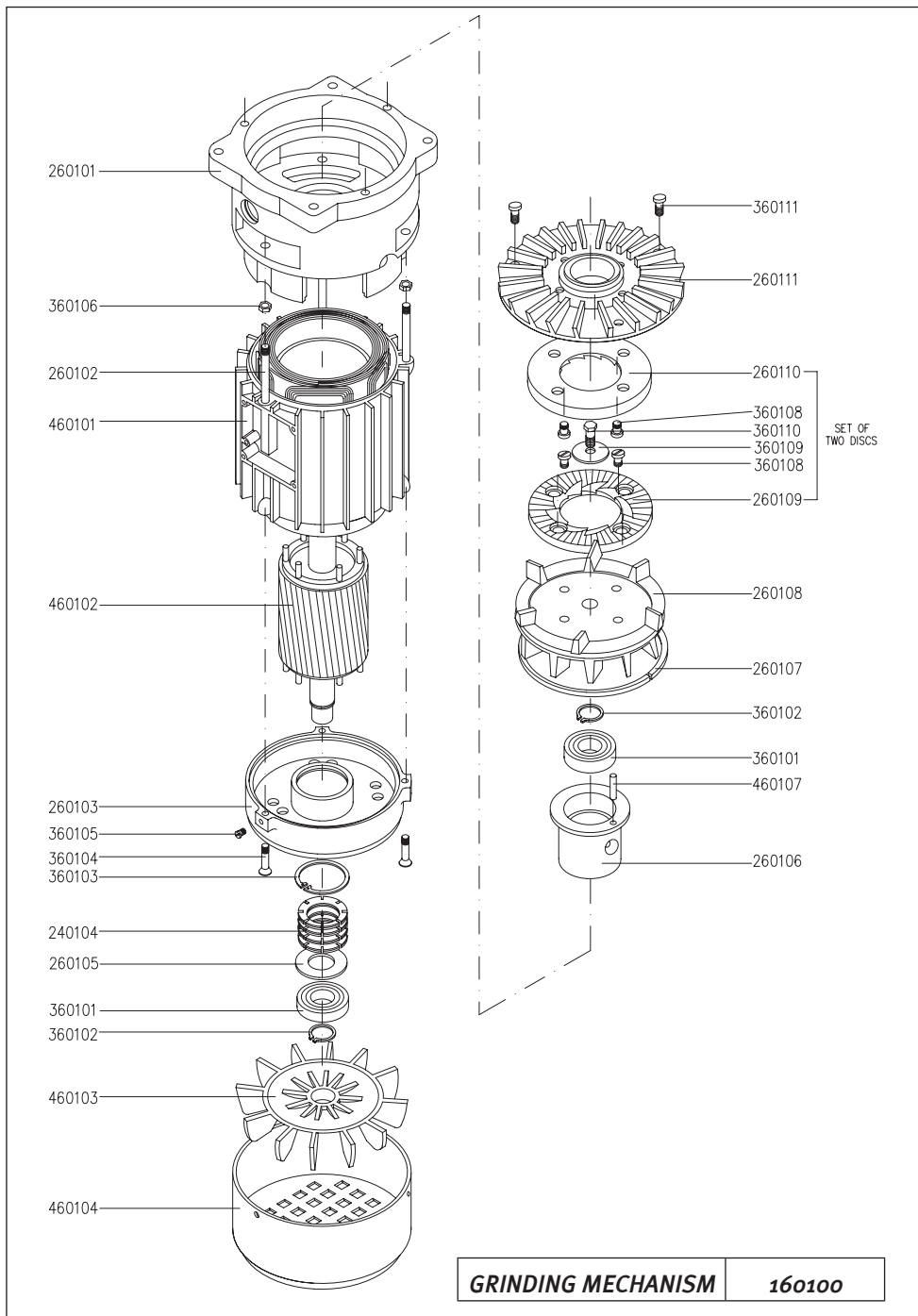

GRINDING MECHANISM | **160100**

240301

260302

360508

360301

260303

340302

340303

340302

260304

230305

230306

230307

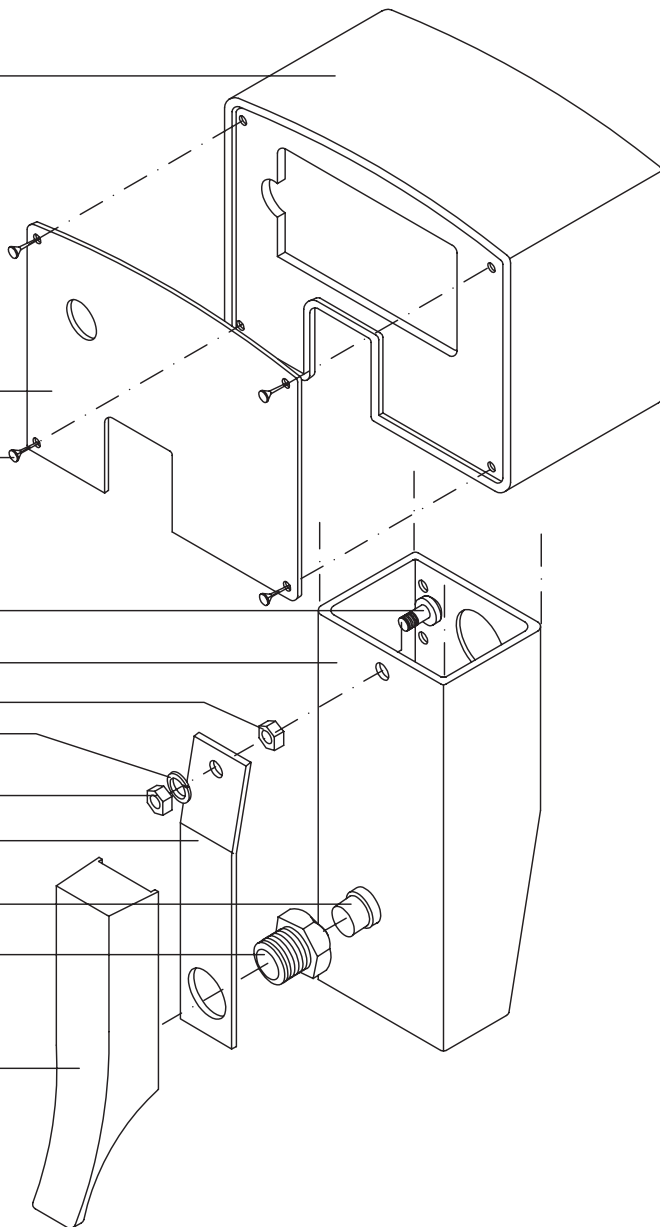

DISCHARGE HOUSING

160300

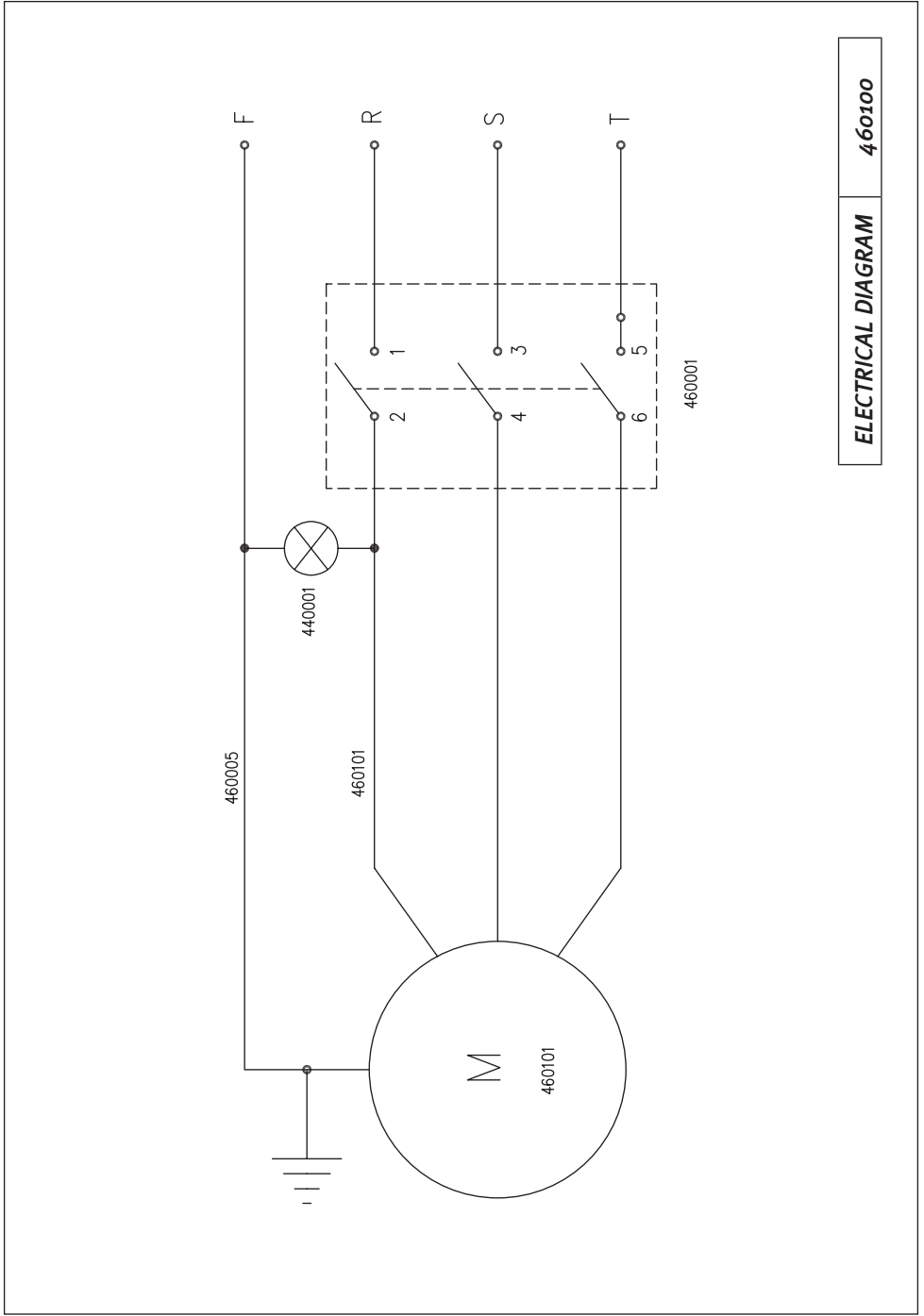

ELECTRICAL DIAGRAM **460100**



The Only Complete Solution When Extremely Stringent Standards Have To Be Met

CE Declaration of Conformity

Manufacturer: **D.I.P. IMPEX S.R.L.**
287, Theodor Pallady Bd., 032258 Bucharest, ROMANIA
TEL +40-21-345 11 06 FAX +40-21-345 11 07
www.dipgrinders.ro • office@dipgrinders.ro

Model: DK-30
DK-40
DK-60

Type of Equipment: Coffee Grinder

Application of Council Directive(s): 73/23/EEC as last amended by EC Directive 93/68/EEC (Low Voltage Directive) and Annex I of Council Directive 73/23/EEC

Testing Provider and Certification Body: TÜV Rheinland Product Safety GmbH, - Am Grauen Stein - D-51105 Köln

Tests: **Certificate of Conformity to the Low Voltage Directive:**
IEC 61010-1:2001 & Annex I of 98/37/EC (Machinery Directive) TÜV Report No. 28200407 002
Registration No. AN 60004699 0001

Certificate of Conformity to Electromagnetic Compatibility
EC Council Directive 89/336/EEC as last amended by EC Directive 93/68/EEC
Tested acc. to: EN 55014-1: 2000+A1+A2
EN 61000-3-2: 2000
EN 61000-3-3: 1995+A1
EN 55014-2: 1997+A1
TÜV Report No. 28200461 001
Registration No. AE 60004700 0001

I, the Undersigned, hereby declare that the equipment above conforms to the above Directives and Standards, also with the Directives CEI EN 602041 and EN 55022.

Place of Issue: Bucharest, ROMANIA

Date of Issue: August 7, 2003

Valentin Diaconu - President

From coffee roasters, supermarkets to coffee shops, the speed of **DK-50/DK-60** is the key feature that makes them unique.

Along with their ability to uniform grinding at all settings, **DK-50/DK-60** are machines with exceptional grinding performance.

- Large grinding capacity at all settings
- Cool and homogeneous grinding performance that preserves coffee's aroma
- Step-less grind adjustment of grinding fineness
- Accurate, wear resistant burrs
- Disks can be re-sharpened 2-3 times
- Easy to calibrate, clean and maintain

Technical information	DK-50	DK-60
Voltage / Frequency	220-230V / 50Hz	380-400V / 50Hz
Motor power	1,5 kW	1,7 kW
Average grinding capacity*	1400 g/min.	2000 g/min.
Hopper capacity	1300 g	1300 g
Hopper magnet	Yes	Yes
Grinding disc diameter Ø	120 mm	140 mm
Net weight	35 kg	32 kg
Dimensions (w x d x h)	250 x 280 x 630 mm	250 x 280 x 630 mm
CE- Conformity	Yes	Yes
Standard colour	Black	Black

** The output can vary according to coffee beans type and roasting method
Additional electrical specifications are available upon request
Special colours can be ordered, please consult with our commercial dept.*



HEAD OFFICE:

287 Theodor Pallady Bd. 032258 Bucharest, Romania
 Phone: +40 21 345 11 06 • Fax: +40 21 345 11 07
 www.dipgrinders.ro • office@dipgrinders.ro